

# EE 320 L      ELECTRONICS I

## LABORATORY 6: PCB LAYOUT DESIGN

DEPARTMENT OF ELECTRICAL AND COMPUTER ENGINEERING  
UNIVERSITY OF NEVADA, LAS VEGAS

### 1. OBJECTIVE

Learn the tools/software and process of PCB layout design.

### 2. COMPONENTS & EQUIPMENT

PC with PCB design software installed (e.g. EazyEDA, Solidworks, AutoCad/AutoDesk, etc.)

### 3. BACKGROUND

A printed circuit board (PCB) mechanically supports and electrically connects electrical or electronic components using conductive tracks, pads and other features etched from one or more sheet layers of copper laminated onto and/or between sheet layers of a non-conductive substrate. Components are generally soldered onto the PCB to both electrically connect and mechanically fasten them to it. In comparison to breadboard circuits, PCBs require additional design effort to lay out the circuit, but manufacturing and assembly can be automated.

Two technologies of PCBs are usually used or combined: through-hole and surface-mount technology, depending on the component sizes, density and circuit complexity.



Fig. 1. Through-hole technology

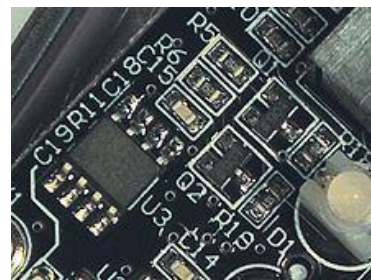
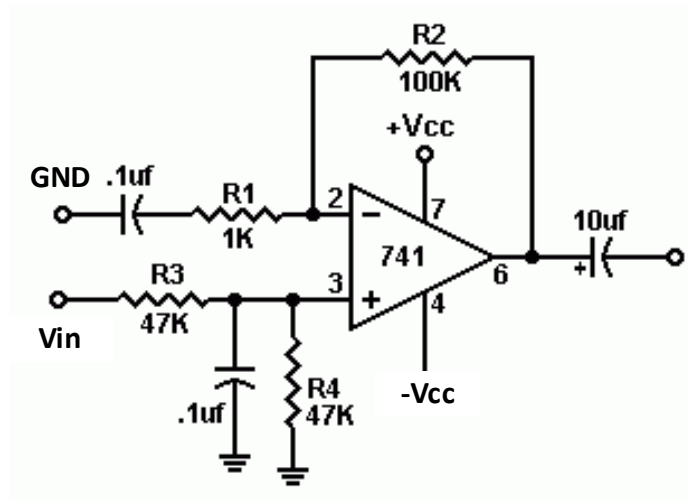

Fig. 2. Surface-mount technology

## 4. LAB DELIVERIES

### LAB EXPERIMENTS:

1. Go through the step-by-step manual with EazyEDA starting at Page 4.
  - Screenshot your final PCB layout design and DRC result.
2. Use EazyEDA to design the PCB layout for the following circuit.
  - Screenshot your schematic, simulation, final PCB layout design and DRC result.



Circuit 1

3. Watch the following videos for PCB design in Solidworks and AutoCad/AutoDesk.
  - Which one do you prefer and why?
  - What can you conclude regarding the PCB design process?
  - 1) <https://www.youtube.com/watch?v=W1AJOOREcP0>
  - 2) <https://www.youtube.com/watch?v=IwpU6uJ-DPU>
  - 3) <https://www.youtube.com/watch?v=VZZBEocoYDA> .

**POSTLAB REPORT:**

Include the following elements in the report document:

Section	Element	
1	<b>Theory of operation</b> <i>Include a brief description of every element and phenomenon that appear during the experiments.</i>	
2	<b>Prelab report</b> 1. Run the LTspice simulation for Circuit 1 in Experiment 2. Assume the input AC source has a $V_{pp} = 1V$ and frequency of 1KHz. Run the AC analysis for Bode plot from 10Hz to 1MHz as well.	
3	<b>Results of the experiments</b>	
	<b>Experiments</b>	<b>Experiment Results</b>
	1	Screenshots of LTspice simulations and oscilloscope waveforms, and $V_p$ , $V_{pp}$ values.
	2	Screenshots of LTspice simulations and oscilloscope waveforms, and $V_p$ , $V_{pp}$ values.
4	<b>Answer the questions</b>	
	<b>Questions</b>	<b>Questions</b>
	1	Answer the questions in Experiment 3.
5	<b>Conclusions</b> <i>Write down your conclusions, things learned, problems encountered during the lab and how they were solved, etc.</i>	
6	<b>Images</b> <i>Paste images (e.g. scratches, drafts, screenshots, photos, etc.) in Postlab report document (only .docx, .doc or .pdf format is accepted). If the sizes of images are too large, convert them to jpg/jpeg format first, and then paste them in the document.</i>	
	<b>Attachments (If needed)</b> <i>Zip your projects. Send through WebCampus as attachments, or provide link to the zip file on Google Drive / Dropbox, etc.</i>	

**5. REFERENCES & ACKNOWLEDGEMENT**

1. Adel S. Sedra & Kenneth C. Smith, "Microelectronic Circuit", 6<sup>th</sup> Ed.
2. Online sources:  
Google, Wikipedia, etc.  
[https://en.wikipedia.org/wiki/Printed\\_circuit\\_board](https://en.wikipedia.org/wiki/Printed_circuit_board)
3. Related circuit component datasheets.

I appreciate the help from faculty members and TAs during the composing of this instruction manual. I would also thank students who provide valuable feedback so that we can offer better higher education to the students.

## Step-by-Step PCB Design Flow with EazyEDA

This manual aims to introduce how to use EazyEDA for circuit simulations and PCB design.

### Step 1: Start the EazyEDA.

You can either use the online application (<https://easyseda.com>) or download the “Desktop Client”. It’s a free application. For online version, if you are a new user, you need to register an account first. After signing in, click the “Products” and choose the “Online Editor”.

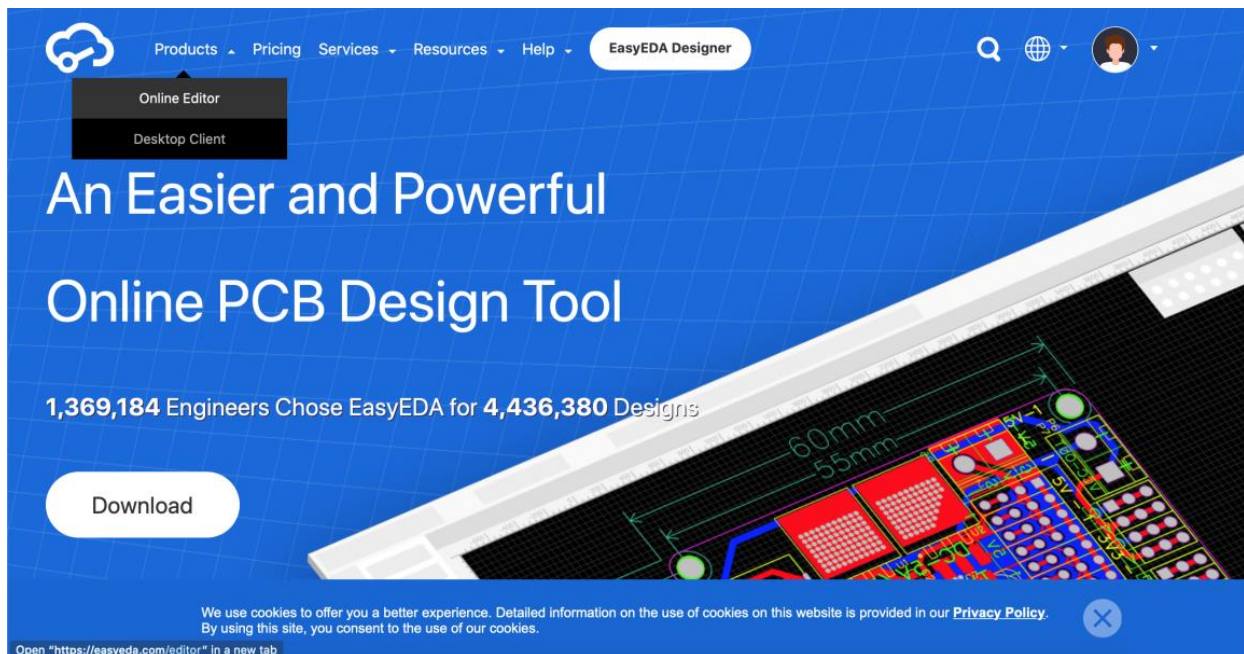

### Step 2: Change to **Simulation Mode** and create a **New Project**.

- Here you can use the “**Spice Library**”

\*The standard mode may not have the library you need, and you cannot do circuit simulations with the standard mode.

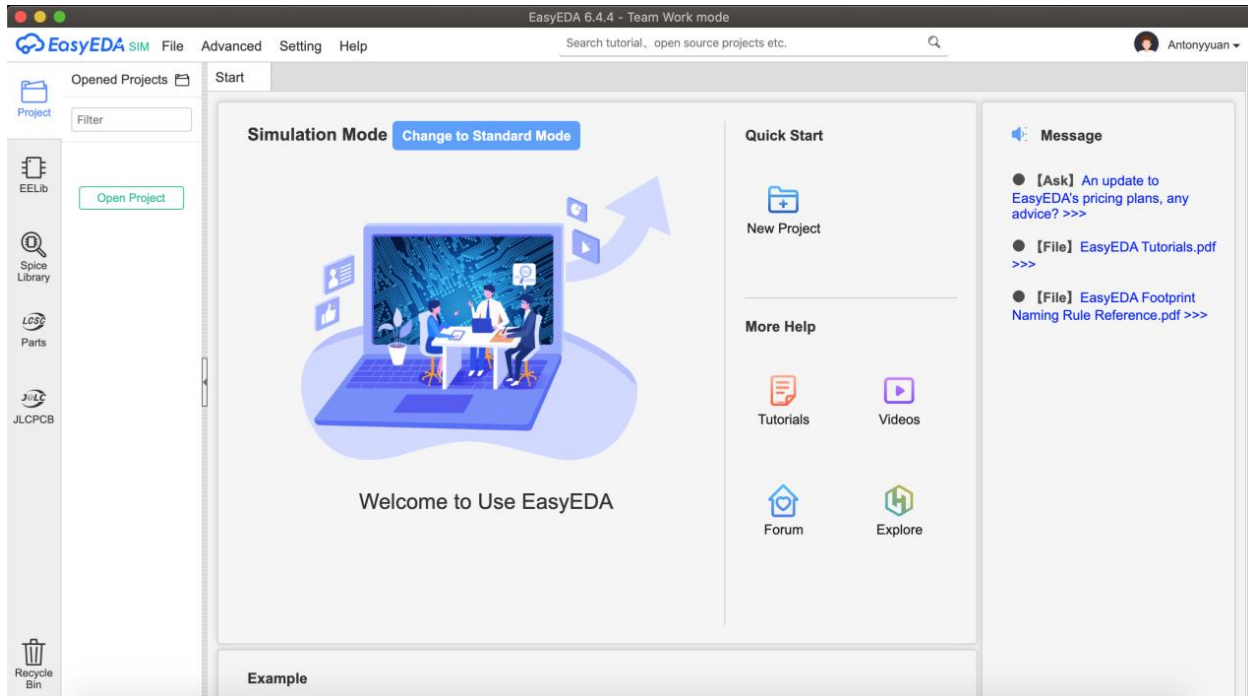

**Step 3:** Click “Spice Library” and find **power source** (DC voltage source), **resistors** and **multimeter** (ammeter & voltmeter).

- Click the “Place” button to put them into the schematic, and add **ground**.

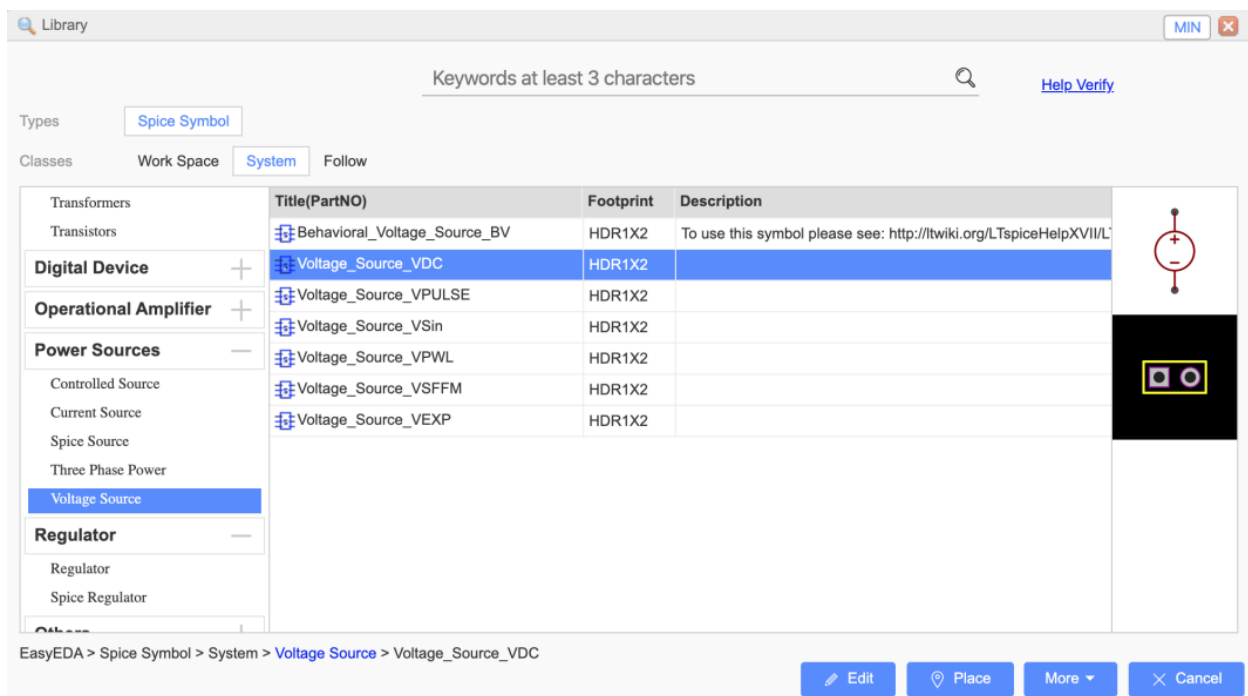





Library MIN X

Keywords at least 3 characters Help Verify

Types

Classes

Keyword to Filter	Title(PartNO)	Footprint	
<b>Analog Devices</b> Capacitor Diodes Inductor Operational Amplifier Regulator <b>Resistor</b> Spice Discrete Transformers Transistors	Resistor1_EU	AXIAL-0.3	
	Potentiometer_EU	RES-ADJ_3386P	
	Resistor2_EU	AXIAL-0.3	
	Potentiometer_US	RES-ADJ_3386P	
	Resistor1_3D	AXIAL-0.3	
	Resistor2_3D	AXIAL-0.3	
	Potentiometer_3D	3362P	
	Resistor2_US	AXIAL-0.3	
	Resistor1_US	AXIAL-0.3	



EasyEDA > Spice Symbol > System > Resistor > Resistor1\_EU

Library MIN X

meter Help Verify

Types

Classes

Keyword to Filter	Title(PartNO)	Footprint	
<b>Analog Devices</b> <b>Digital Device</b> <b>Operational Amplifier</b> <b>Power Sources</b> <b>Regulator</b> <b>Others</b>	Multimeter		
	Potentiometer_EU	RES-ADJ_3386P	
	Wattmeter		
	Potentiometer_3D	3362P	
Potentiometer_US	RES-ADJ_3386P		

EasyEDA > Spice Symbol > System > Instrument > Multimeter

- After selecting one or more items, you can rotate the selected items using: **Top Menu > Format > Rotate Left/Right** or by pressing the default rotate hotkey: **Space**

EasyEDA SIM File Edit Place Format View Simulation Advanced Setting Help Antonyyuan

Selected Objects 0

- Use the **Wiring Tools** to wire them up

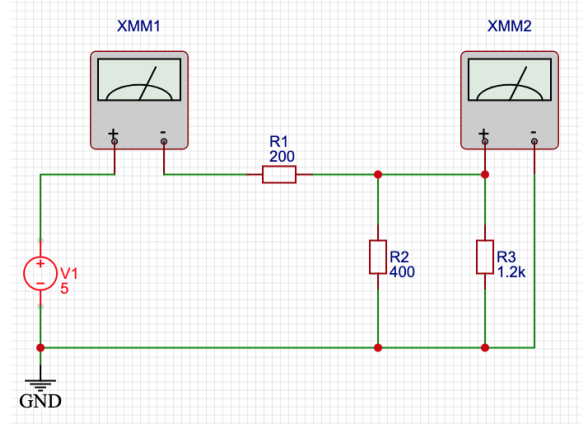
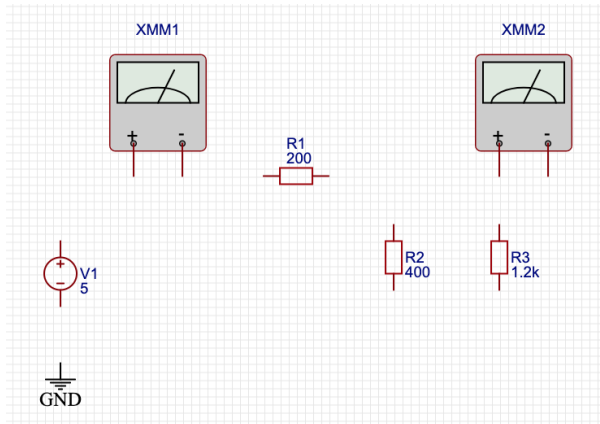

**Step 4:** Click the components for editing.

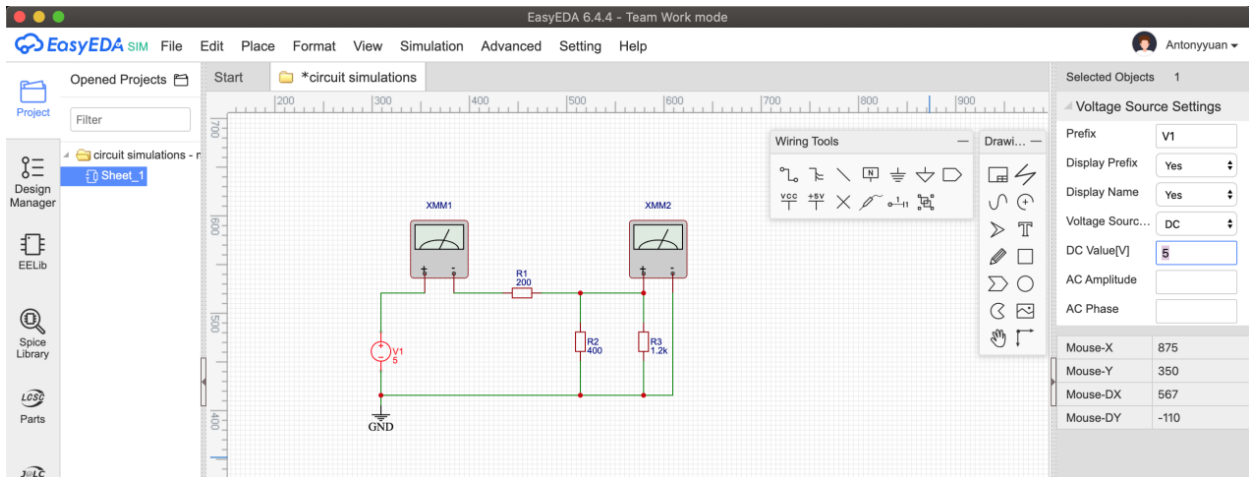

Selected Objects 1

**multimeter Settings**

Prefix:

Display Prefix:

multimeter type:

Mouse-X	845
Mouse-Y	580
Mouse-DX	480
Mouse-DY	16.66

Selected Objects 1

**Resistor Settings**

Prefix:

Display Prefix:

Display Name:

Resistance[Ω]:

Mouse-X	845
Mouse-Y	495
Mouse-DX	385.83
Mouse-DY	-27.5



**Step 5: Run the simulation (Top Menu > Simulation > Run your simulation)**

- Observe the current and voltage readings on multimeters.

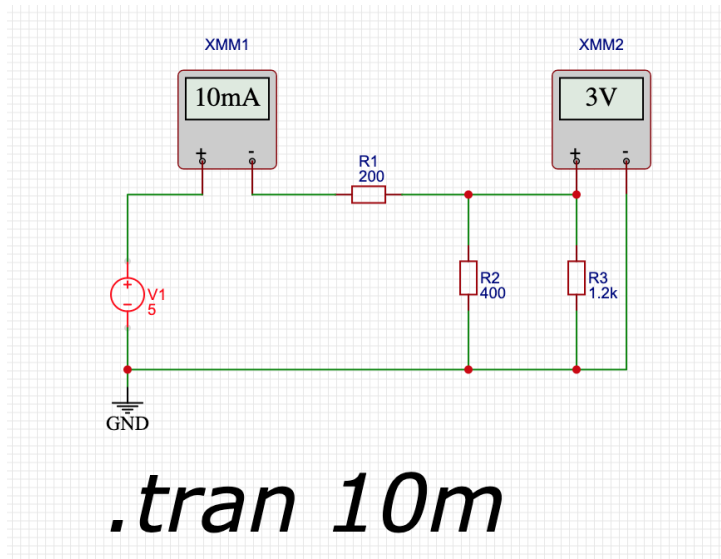
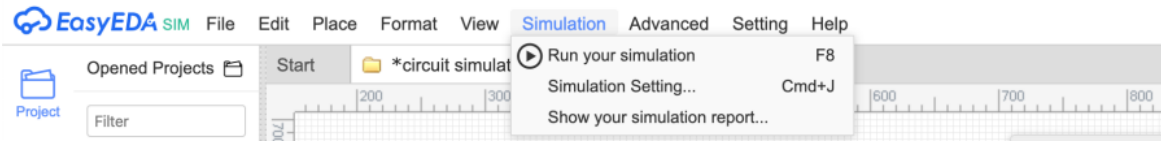

**Step 6:** After simulating the circuit, remove all the multimeter in the schematic, and we are going to do the PCB design.

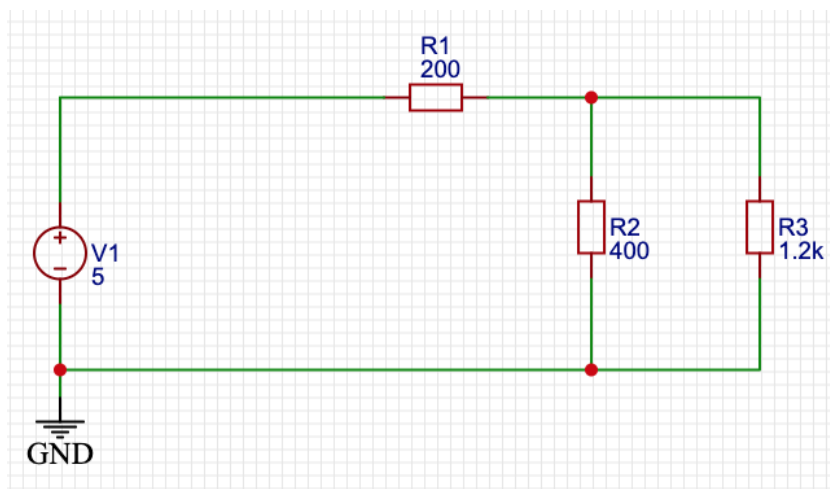



**Step 7:** Convert your schematic to PCB (Top Menu > Design > Convert to PCB).

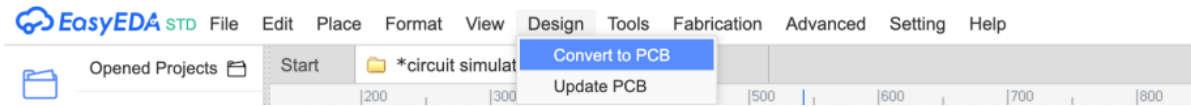

Choose the appropriate shape and size of your PCB, and click the apply button for the next step.

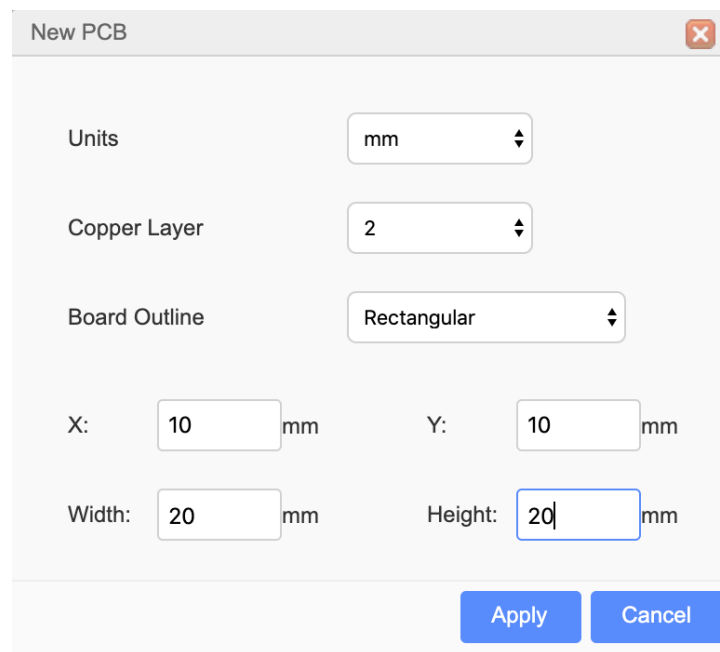

**Step 8:** Move all the components/objects on the PCB.

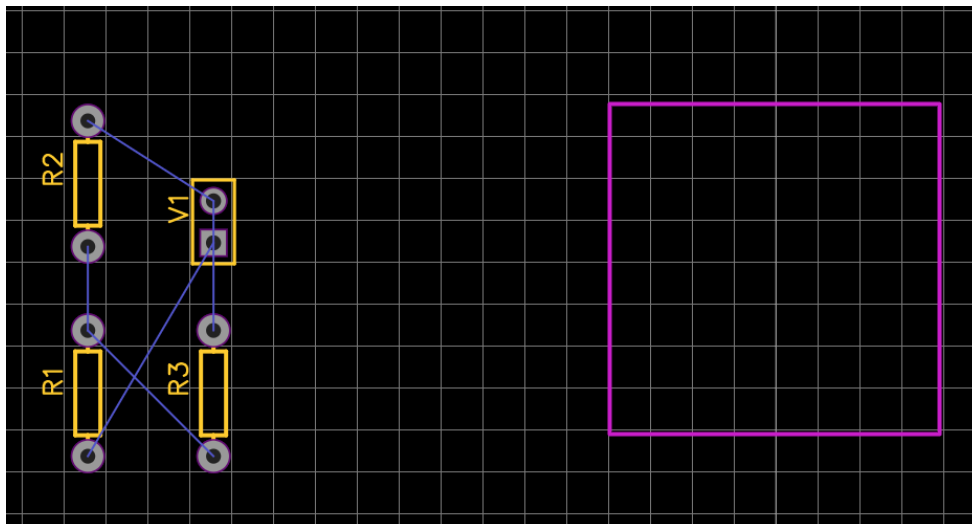

You can arrange all the objects by yourself, but also you can use **Auto Router** to help you (**Top Menu > Route > Auto Route**). Auto Router is easily and quickly, but you have to double check and make sure your PCB design is eligible for **DRC (Design Rule Checking)**.

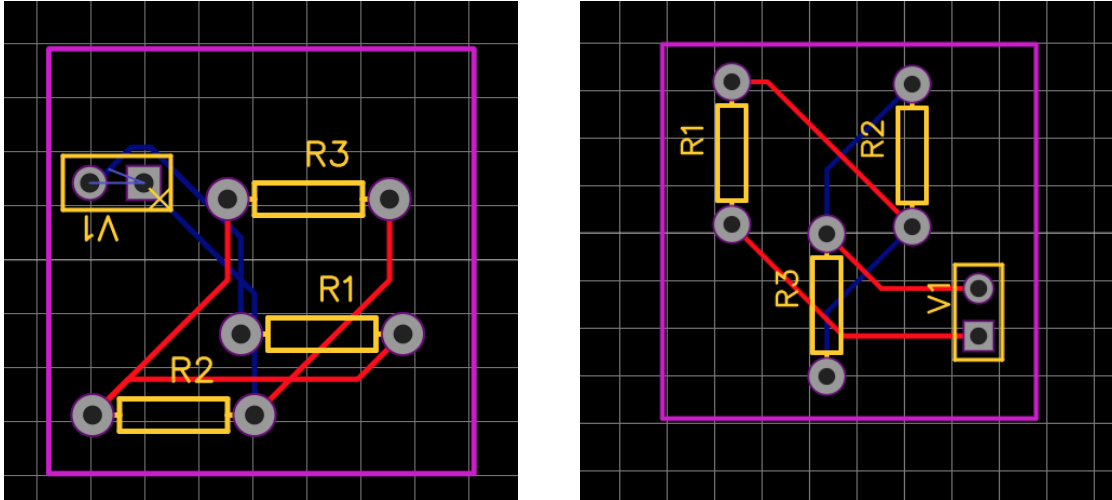

Tips: What is PCB Design Rule Check? Design rule checking or check(s) (DRC) is the area of electronic design automation that determines whether the physical layout of a particular chip layout satisfies a series of recommended parameters called design rules.

**Step 9:** After you finish your PCB design, you need to use the “**Check DRC**” to help you check the route again (**Top Menu > Design > Check DRC**).

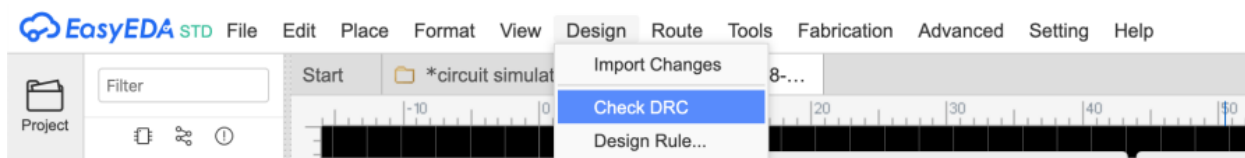

\*\* If your design has **DRC Errors**, you should click each of the error and fix them one by one. I suggest you use “**Check DRC**” frequently, before too many errors overwhelm you at the end of design.

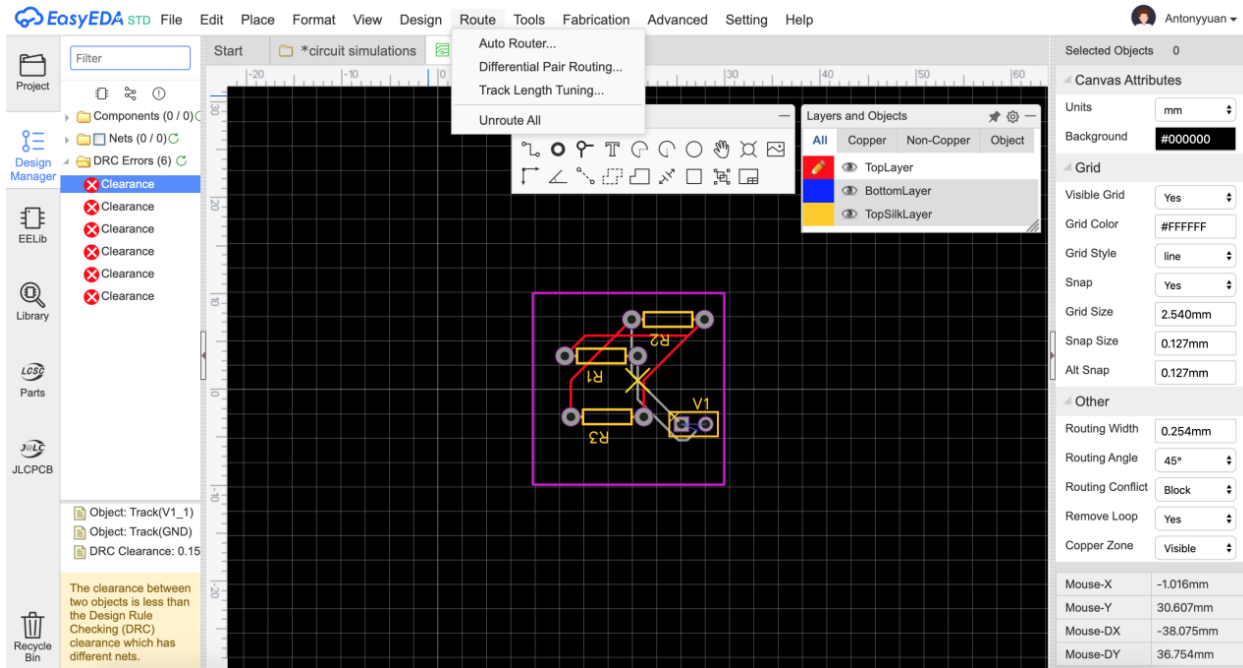

If your design has 0 error. Congratulations, you are able to go to the next step.

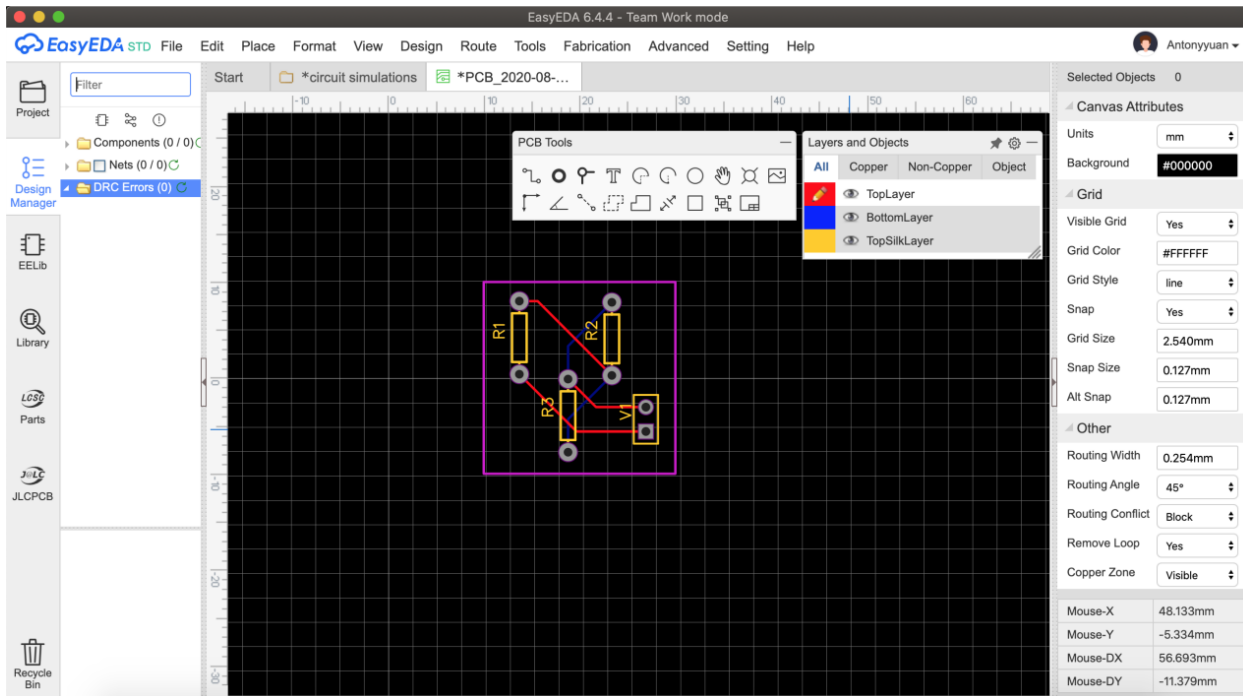

**Step 10:** Export your PCB design. You can export your file to the format you want.

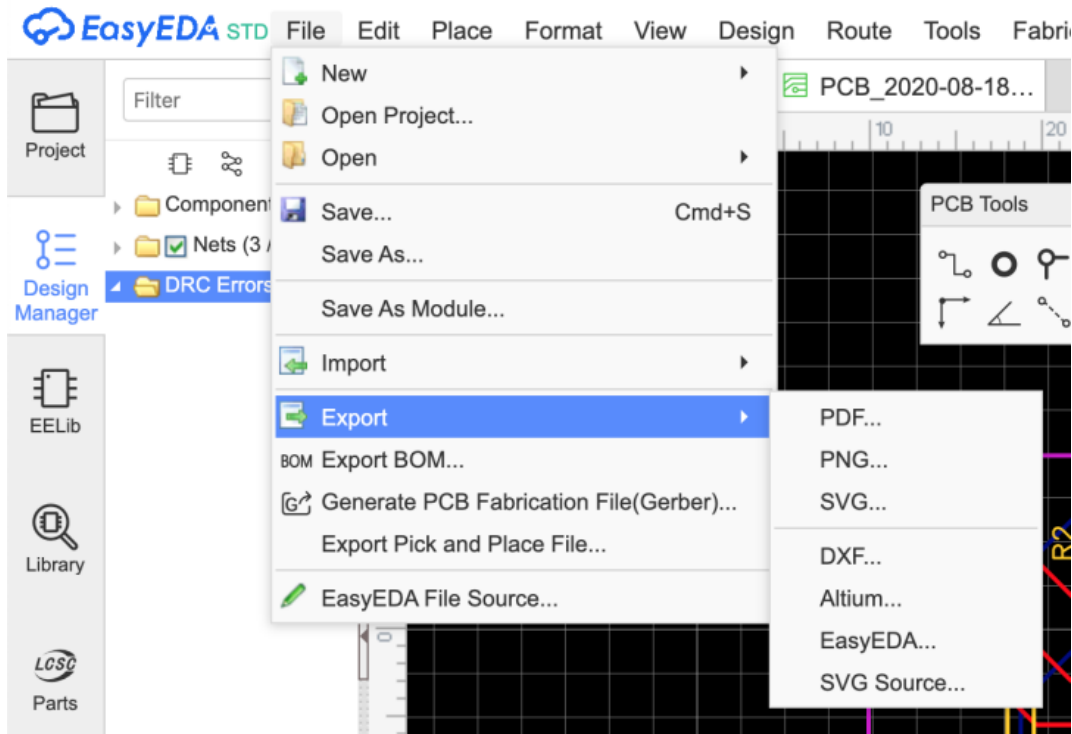

**Optional for future project (e.g. Senior Design, etc.):** You can also choose to fabricate your PCB by using the “Fabrication” in EazyEDA (**Top Menu > Fabrication**). You can use any vendors you would like to fabricate your PCB designs.

